

# F-CMUX-BIDI8-A/B LGX2

8 channel CWDM single fiber mux/demux

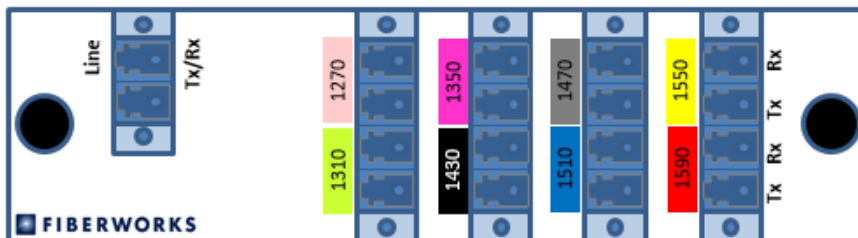
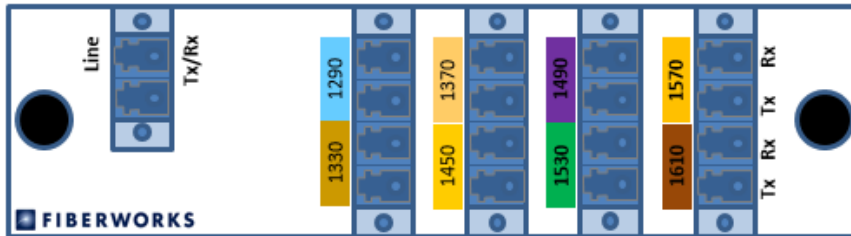

## DESCRIPTION

These compact CWDM multiplexers/demultiplexers work in a pair to provide 8 bidirectional channels on a single strand of fiber. They use 16 CWDM wavelengths in both the lower (1310 nm) and upper (1550 nm) band with 8 wavelengths being used in each direction. The color coding helps in the installation process reducing the chance of errors.

## FEATURES

- Coarse WDM in compliance with ITU-T G.694.2
- Standard 16-channel CWDM band 1270 – 1370 nm and 1430 – 1610 nm, 20 nm spacing
- Based on thin film optics with epoxy free optical path
- Protocol transparent (support 1G, 10G etc.)
- 3 modules fit in 1U in 19" rack or 12 modules in a 3U chassis
- LC/UPC connectors

## FUNCTIONAL DESCRIPTION

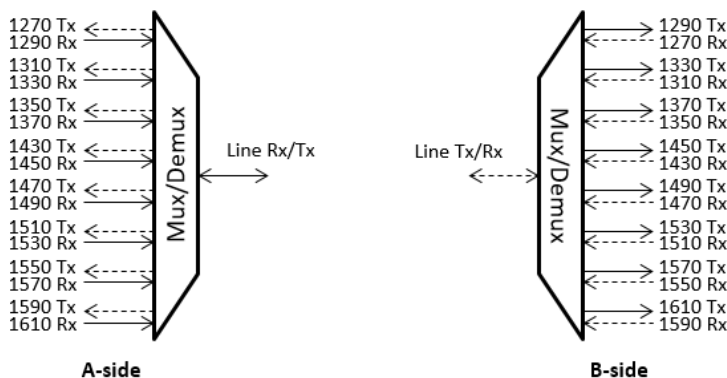

**TECHNICAL DATA**

Parameter	Unit	Value
Center Wavelength	nm	1271 - 1371 and 1431 - 1611
Center Wavelength Accuracy	nm	± 0.5
Channel Spacing	nm	20
Channel Bandwidth	nm	+/- 6.5
Max insertion loss (module / link)	dB	< 3.5 / < 5.0
Channel Flatness	dB	< 0.5
Channel Uniformity	dB	< 1.0
Adjacent channel isolation	dB	> 30
Non-adjacent channel isolation	dB	> 40
Directivity	dB	> 50
Return Loss	dB	> 45
PDL	dB	< 0.10
PMD	ps	< 0.1
Wavelength thermal stability	nm/°C	< 0.002
Insertion Loss thermal stability	dB/°C	< 0.003
Power Handling	mW	< 300
Operating temperature	°C	-30 to +70
Storage temperature	°C	-40 to +85
Dimensions (H x W x D)	mm	35 x 130 x 210

Note: Insertion loss values are valid for 0 – 70 °C. For temperatures from 0 to -30 °C add 0.5 dB for module and 1.0 dB for link.

**ORDERING INFORMATION**

Product number	Description
F-CMUX-BIDI8-A-LGX2	Fiberworks 8 ch. CWDM BiDi Mux/Demux LGX2 Single fiber, LC/UPC, A-side
F-CMUX-BIDI8-B-LGX2	Fiberworks 8 ch. CWDM BiDi Mux/Demux LGX2 Single fiber, LC/UPC, B-side
F-CHASSIS-19-LGX2-12	Fiberworks 19" 3U LGX2 chassis for 12 modules, rear access
F-CHASSIS-1U3-LGX2	Fiberworks 19" 1U LGX2 chassis for 3 moduler, åpen foran og bak.